

# 110x110x20mm

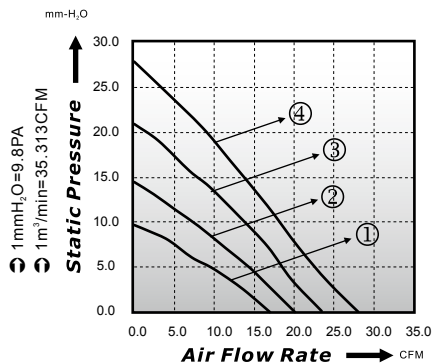

## ■ P-Q Curve (At Rated Voltage)



## ■ Dimensions Drawing

Unit: (mm)

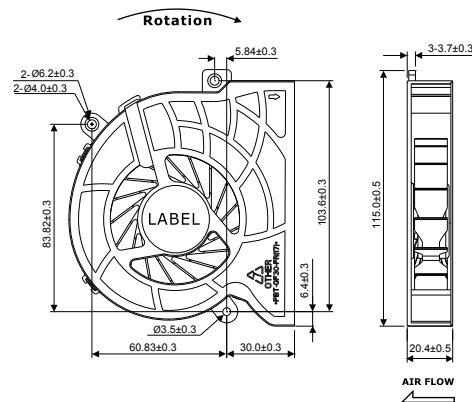

Model No	Bearing (*)	Rated Voltage (VDC)	Rated Current (A)	Power Consumption (Watts)	Speed (rpm)	Air Flow (CFM)	Static Pressure (mmH <sub>2</sub> O)	Noise (dBA)	Curve
EBD11020-12L*	○ ● ⊖	12	0.25	3.00	2500	16.93	9.72	34.5	1
EBD11020-12M*	○ ● ⊖	12	0.45	5.40	3000	20.11	14.48	40.6	2
EBD11020-12H*	○ ● ⊖	12	0.70	8.40	3500	23.48	20.99	45.7	3
EBD11020-12HH*	○ ● ⊖	12	0.90	10.80	4000	27.98	27.84	49.2	4

\* Bearing Type: ○ Sleeve ● Two Ball ⊖ Hydro-Dynamic